

2600 SERIES

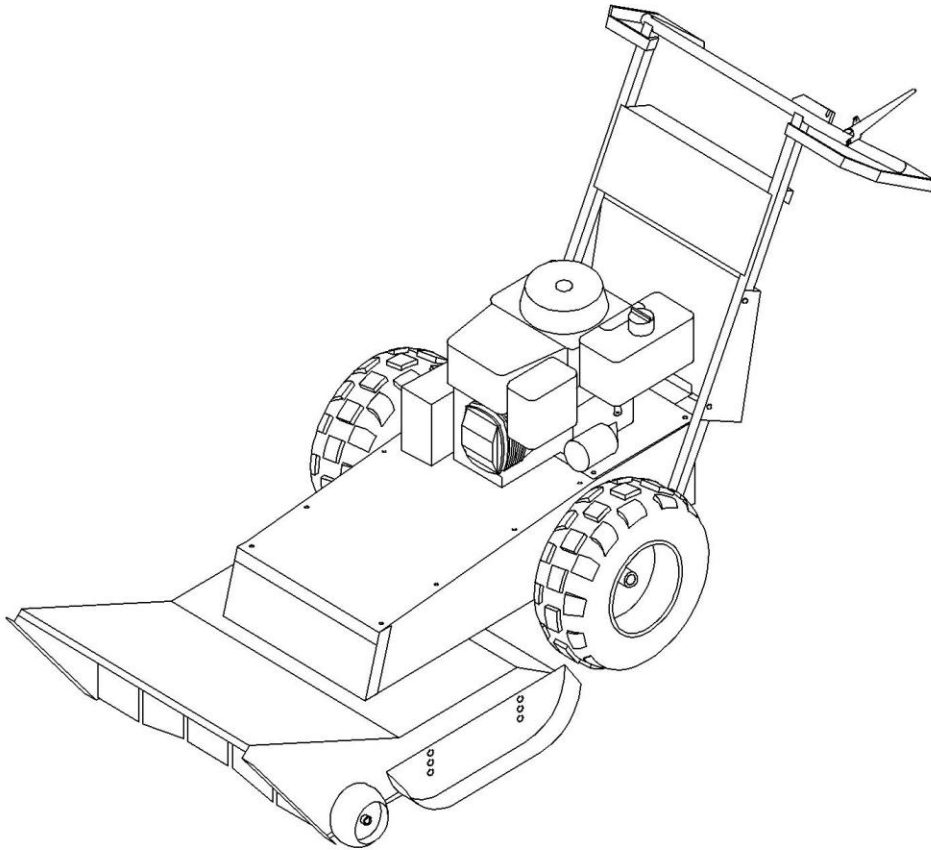

BRUSH OX
BROWN PRODUCTS, INC



Owners/Operators Manual



BROWN
PRODUCTS, INC

376 COUNTY ROAD 563
MIDLAND CITY, AL 36350

PH: (800) 897-3726 · FAX: (334) 983-1606

www.brownproducts.com

⚠ WARNING



Before operating your machine, stop and read this owners manual. Do not attempt to operate the unit until you fully understand the material covered in this manual. Without the knowledge contained in this manual, injury or death can result.

Equipment Safety

⚠ Warning: Read this manual before operation.

Operators of the equipment must read and understand this manual. Failure to read this manual and follow these safety and operating instructions could result in serious bodily injury or even death.

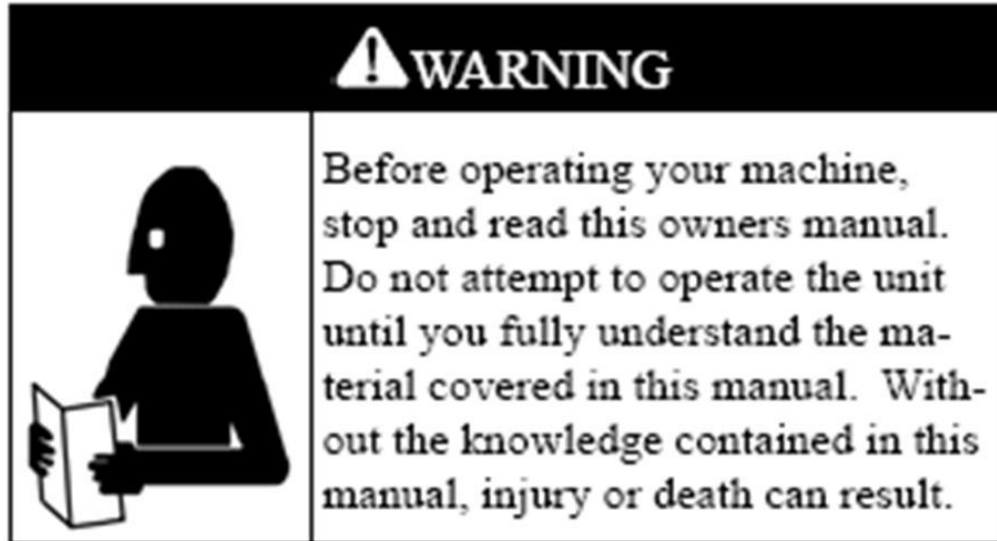

Each operator of the equipment should review this manual every six (6) months. You are encouraged to duplicate this manual and store for safe keeping in the event that the original is lost or damaged. Additional copies are available from Brown Products, Inc. at no charge.

Equipment Safety

Recognize safety information:

This is the safety alert symbol. When you see this symbol on Your equipment or in this manual, be alert to the potential for personal injury or injury to others.



Understand signal words:

CAUTION used without the safety alert symbol indicates a Potentially hazardous situation which, if not avoided, may result in property damage.

CAUTION

CAUTION indicates a potentially hazardous situation which, if not avoided, may result in minor or moderate injury.



WARNING indicates a potentially hazardous situation which, if not avoided, could result in death or serious injury.



DANGER indicates an imminently hazardous situation which, if not avoided, will result in death or serious injury.



Follow safety instructions:

- Read owner/operator manual.
- Replace missing or damaged safety decals.
- Safety decals and this manual must be considered a permanent part of your equipment.
- Should ownership of the equipment be transferred, this manual must also be transferred.
- Unauthorized modifications to the equipment are not recommended. This could impair the function, safety, and life of the machine.
- For any part of this manual that you do not understand, contact your dealer or Brown Products, Inc. at (800) 897-3726.
- All equipment with moving parts are potentially dangerous. Due to this fact, there is no substitute for a safe, knowledgeable operator. It is important that all persons operating this equipment read, understand, and follow the instructions provided in this manual.

Equipment Safety

Safety Decals

The following safety decals should be attached to the equipment at all times. Should any decals become damaged or lost, it is the responsibility of the owner to replace it. Additional decals may be obtained from the dealer or Brown Products, Inc. at no charge.

<p>⚠ WARNING</p> <hr/> <p>HELP AVOID INJURY</p> <ul style="list-style-type: none">• Read owner's manual• Always wear eye protection• Keep shields in place• Keep others away

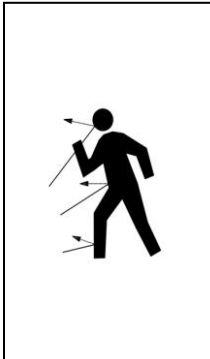
<p>⚠ DANGER</p> <hr/> <p>Thrown Object Hazard</p> <p>To prevent serious injury or death from thrown objects:</p> <ul style="list-style-type: none">• Stay clear when blade is turning• Operate only with all guards installed and in good condition.• Stop operation if bystanders come within 150 feet.	
--	---

Equipment Safety

Safety Decals (continued)

<p>⚠ DANGER</p>	<p>⚠ PELIGRO</p>
	<p>CHUCHILLAS ROTATIVAS</p> <p>Para precaverse de lesiones graves o de accidentes mortales causados por las cuchillas rotativas:</p> <ul style="list-style-type: none"> • Manténganse a distancia estando funcionando las cuchillas o el motor. • No pongan las manos ni los pies debajo de la plataforma estando en marcha el motor.
<p>ROTATING BLADES</p> <p>To prevent serious injury or death from rotating blades:</p> <ul style="list-style-type: none"> • Stay clear when blades are turning or engine is running. • Do not place hands or feet under deck when the engine is running. 	<p>⚠ DANGER</p>
	<p>LAMES ROTATIVES</p> <p>Prévenir les blessures graves et la mort que peuvent causer les lames rotatives:</p> <ul style="list-style-type: none"> • Rester éloigné quand les lames tournent ou que le moteur tourne. • Il est interdit de mettre les mains ou les pieds sous le capot quand le moteur tourne.

<p>⚠ WARNING</p>	<p>⚠ ADVERTENCIA</p>
	<p>PELIGRO DE PIEZA EN MOVIMIENTO</p> <p>Para precaverse de lesiones graves o de accidentes mortales que producirse por las piezas en movimiento:</p> <ul style="list-style-type: none"> • Instalen y aseguren todos los resguardos y cubiertas antes de hacer arrancar la máquina. • Guarden las manos, los pies, el pelo y las ropas alejados de las piezas en movimiento. • Antes de hacer un ajuste o reparación cualquiera, paren y echen el cerrojo al tomafuerza. • El subirse a la máquina cuando funciona está prohibido.
<p>MOVING PART HAZARD</p> <p>To prevent serious injury or death from moving parts:</p> <ul style="list-style-type: none"> • Close and secure guards and shields before starting. • Keep hands, feet, hair and clothing away from moving parts. • Disconnect and lockout power source before adjusting or servicing. • Do not stand or climb on machine when operating. 	<p>⚠ ADVERTISSEMENT</p>
	<p>PIÈCE EN MOUVEMENT</p> <p>Dans le but de prévenir les blessures graves ou la mort pouvant être causés par les pièces en mouvement:</p> <ul style="list-style-type: none"> • Poser et fixer tous les gardes et capots avant de mettre la machine en marche. • Garder les mains, les pieds, les cheveux et les vêtements loin des pièces en mouvement. • Avant de procéder à l'entretien ou au réglage, désengager et verrouiller la prise de force. • Il est interdit de monter sur la machine quand elle est en marche.

Equipment Safety

Safety Decals (continued)

⚠️ WARNING
⚠️ ADVERTENCIA
⚠️ ADVERTISSEMENT

EYE HAZARD <ul style="list-style-type: none"> • Wear eye protection when using this equipment. • Do not direct discharge toward others.
PELIGRO OCULAR <ul style="list-style-type: none"> • Cuando utilice esta segadora use gafas de protección. • No dirijan la descarga hacia donde hubiere gente.
RISQUE POUR LES YEUX <ul style="list-style-type: none"> • Porter des lunettes protectives au moment d' utiliser cette machine. • Interdit de diriger la décharge de la machine vers les personnes.

⚠️ WARNING
NO STEP

⚠️ WARNING
TILTING UNIT MORE THAN 20° CREATES A THROWN OBJECT HAZARD AND MAY DAMAGE ENGINE
<i>DO NOT TILT THIS LINE PAST HORIZONTAL</i>

⚠️ WARNING
Gasoline is highly flammable and explosive. Turn engine off and let cool before refueling.
The engine emits toxic carbon monoxide. Do not run in an enclosed area.
Read owner's manual before operation.

Equipment Safety

Safety Decals

Safety decals must be positioned as illustrated below. Use this diagram to correctly identify missing, damaged, or illegible decals for replacement.

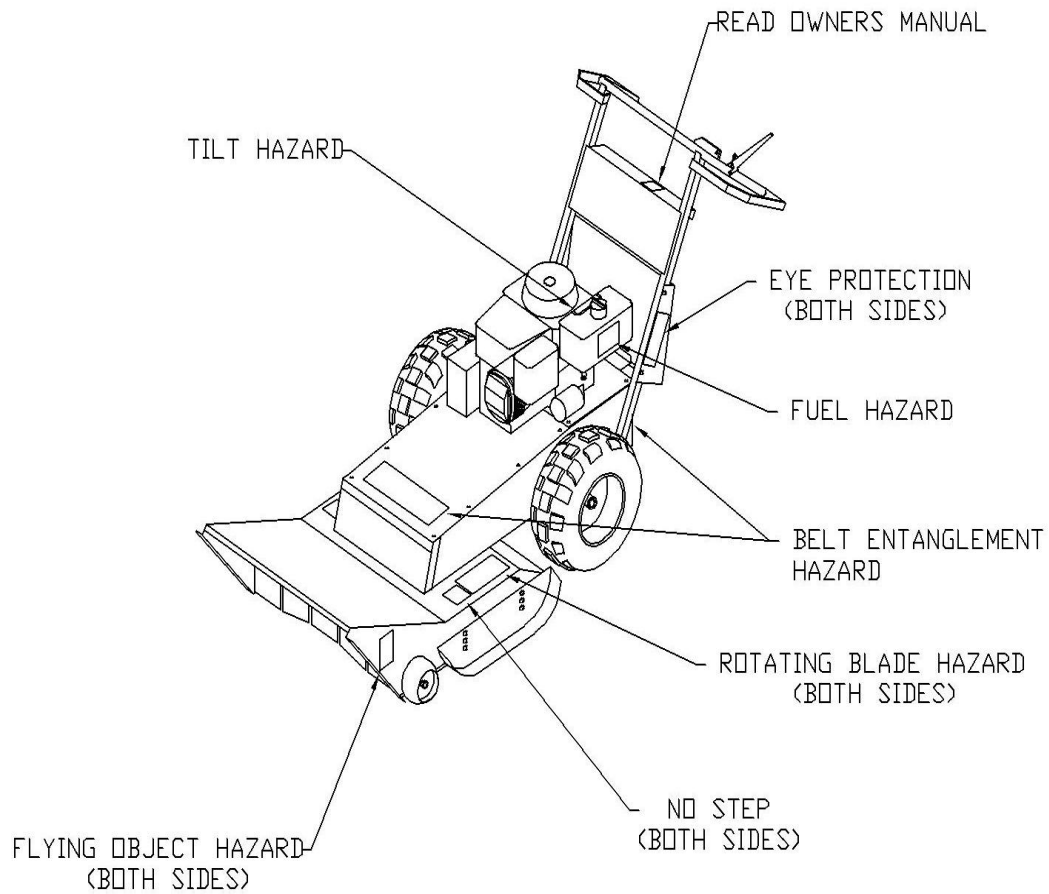

Equipment Safety

Safety Precautions

⚠ WARNING! Transport with care. Before transporting, lock parking brake and strap unit securely using the bar across top of cutter deck. **Never depend on parking brake alone!**

⚠ DANGER! Protect bystanders, clear work area of debris. Do not operate the cutter near people. Debris can be thrown hundreds of feet. Clear work area of foreign objects such as wire, glass, and other debris. Debris thrown by the cutter can cause serious injury or death.

⚠ CAUTION! Avoid fires. Keep the machine clean of debris, trash, and any other flammable material.

⚠ WARNING! Check equipment before operating. Tighten all nuts and bolts before operating. Make certain that equipment is lowered to ground before attempting to make adjustments or perform maintenance. Replace or repair any safety device, bolts, etc. if damaged or worn.

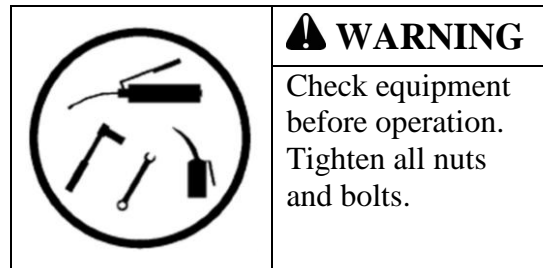
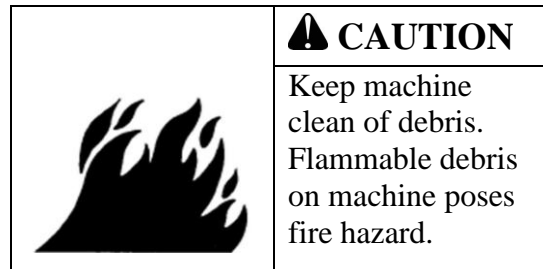
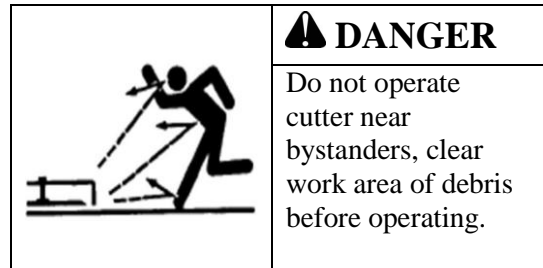

Equipment Safety

Additional Safety Precautions

⚠ DANGER! Stay clear of rotating blades.
The cutter is designed to cut grass and brush up to 2 ½” in diameter. **Keep hands and feet From under cutter deck!**

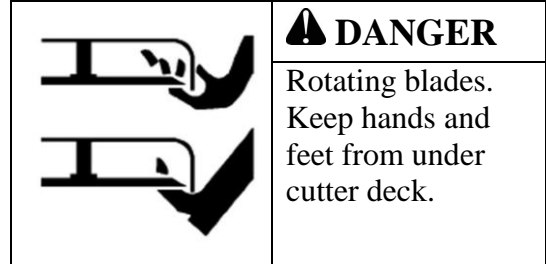

⚠ WARNING! Wear protective clothing.
Wear close-fitting clothing and other protective Devices appropriate for the job.

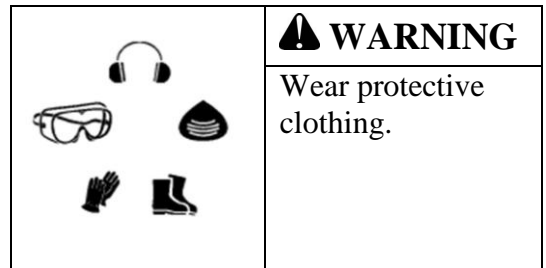

⚠ WARNING! Slopes and rough terrain.
When operating on slopes or rough terrain, decrease travel speed. Do not operate in an area where the unit could roll over.

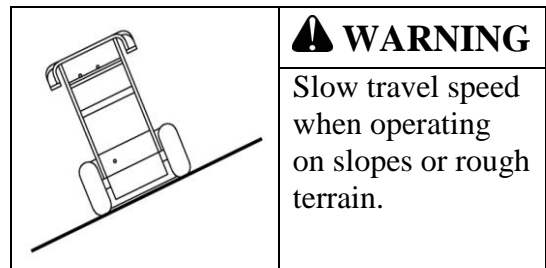

⚠ DANGER! Tighten blade bolts.
Blade bolts will stretch with use and must be Tightened. Follow maintenance instructions In this manual. **If cutter is operated with loose Blade bolts, blades and blade carrier will be Damaged. Operation with damaged blades And blade carrier will lead to blade ejection And will cause serious injury or death.**

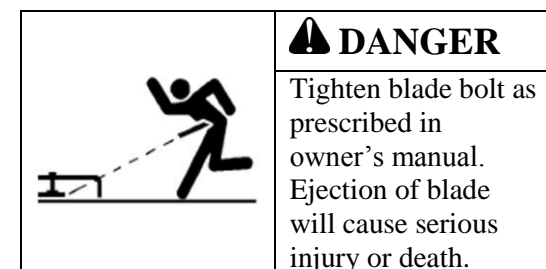

Equipment Safety

Additional Safety Precautions

⚠ DANGER! Keep riders off machine.
Riders can be seriously injured or killed by entanglement or by falling.

⚠ DANGER
Riders can be injured or killed. Keep riders off machine.

⚠ WARNING! Hazardous service conditions.
While working under the cutter deck, be aware of safety hazards. Follow safety precautions specified in this manual. Failure to exercise caution may lead to serious injury or death.

⚠ WARNING
Exercise caution while working under cutter deck. Failure to heed warnings may lead to serious injury or death.

⚠ DANGER! Maintain safety distance.
The cutter creates a serious discharge hazard. Always maintain a safety distance of at least 150 feet. **Never operate cutter with bystanders present!**

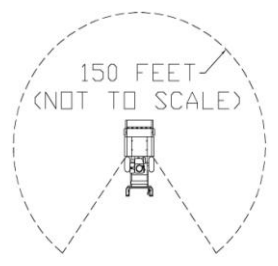
 <p>150 FEET (NOT TO SCALE)</p>	⚠ DANGER Maintain safety distance of at least 150 ft. Failure to do so may cause serious injury or death.
---	---

Operating Instructions

Before starting the BRUSH OX, the operator should:

⚠ WARNING! Read and understand Owner's Manual and all safety instructions and procedures.

NOTICE! Check oil level in engine and add if needed. See engine Owner's Manual for specified oil type.

NOTICE! Check fuel level in fuel tank and fill if needed.

⚠ CAUTION! Check complete BRUSH OX for any loose bolts or nuts. Pay particular attention to the blades and stump jumper. Check blade bolt tightness every four hours of operation.

NOTICE! Assure that the blades are adequately sharp for the task ahead. Remember, you would never use a dull axe to chop down a tree.

⚠ CAUTION! Assure that all five front flappers function properly.

⚠ CAUTION! Assure that the skids are properly fastened and in correct cutting height position. When the unit is sitting on a hard surface, the skids should be approximately 1" off the ground. When the front scalper wheels are in the top position, the skids should be in the middle mounting holes. When the scalper wheels are in the bottom position, the skids should be in the top mounting holes.

NOTICE! Check air pressure in drive tires. Tire pressure should be no less than 14 PSI and no greater than 28 PSI. Each tire is filled with 14 ounces of Flat-Free. Flat-Free can be purchased in quarts (Part # 260-819).

⚠ CAUTION! Assure all other safety devices are in place and functioning properly.

1. Top frame cover plate
2. Front frame closure plate
3. Rear frame closure plate

⚠ CAUTION! Walk through the area to be cut and remove any material that should not come in contact with the cutting blades.

⚠ CAUTION! Assure that no bystanders are within 150 feet of the BRUSH OX at all times.

⚠ CAUTION! Wear long pants, boots, long sleeved shirt, gloves, hat or cap, ear plugs, and eye protection. **DO NOT** operate if not properly clothed.

Operating Instructions (cont'd)

Starting and Operating Instructions:

1. Set Parking Brake. Black knob on rear frame closure plate.
2. Turn fuel ON. Two locations: One in fuel line and one on carburetor.
3. Move Throttle lever to Choke position.
4. Engage starter with ignition key.
5. Once the engine is started, move throttle lever from choke to full throttle.
6. Allow engine to warm up 2-3 minutes before moving the BRUSH OX or engaging the cutting blades.
7. Disengage Parking Brake.
8. Without engaging the cutting blades, drive the machine forward and backward for 1-2 minutes to get a feel for how it handles.
9. The maximum Reverse Speed Control is set at the factory in close proximity to optimum location and should be fine tuned by the dealer prior to delivery. The operator should not tamper with this control until he has several hours' operation experience and feels comfortable with the machine. The Reverse Speed Control stud should **NEVER** be removed from the machine.
10. The maximum Forward Speed Control is set at the factory in close proximity to optimum location for safe and comfortable operation. It should be fine tuned by the dealer prior to delivery. Adjustment can be made with the star shaped knob located on the right handlebar. **DO NOT ADJUST** until comfortable with the operation of the BRUSH OX. **CAUTION! DO NOT ADJUST WHILE MOVING.** When using the Forward Speed Control and the Forward Control Lever and the lever does not make contact with the handlebar **DO NOT INCREASE PRESSURE** on the Forward Lever as it may break the Reverse Control Lever.
11. Forward and Reverse speeds during operation are determined by how far the operator pulls or pushes the Forward and Reverse levers. The BRUSH OX is equipped with a hydrostatic transaxle and has infinite forward and reverse speeds that are determined by the operator.
12. Now that you are comfortable with the forward and reverse motion of the BRUSH OX, it is time to engage the blades. **ALWAYS** engage the blades and operate the BRUSH OX in the Full Throttle position. **DO NOT** run the engine with the Choke activated after it has warmed up.
13. **TO ENGAGE THE BLADES**, place your left hand on the Blade Engage Lever on the left handlebar and slowly push it down to the handlebar. **DO NOT** push the Blade Engage Lever down rapidly as this will stall the engine. Remember, you are starting two blades and a stump jumper from a static position to 1850 RPM.

Operating Instructions (cont'd)

Now you are ready to start operating the BRUSH OX. ALWAYS use caution during cutting operation.

⚠ WARNING! The BRUSH OX will climb up a tree that is too large for it to push over and cut. This will create a **THROWN OBJECT HAZARD** and must be avoided at all times. Also, if the BRUSH OX is tilted more than 20 degrees, the engine can be damaged due to lack of internal lubrication. See the **TILT Decal** on the fuel tank mount to determine 20 degrees.

⚠ DANGER! If the blades fail to stop rotating within 3-4 seconds after releasing the Blade Engage Lever, **STOP USE OF BRUSH OX AND RETURN TO DEALER FOR SERVICE AND REPAIR.**